

PRODUCT DATA SHEET n° 3

STRAIGHT SECTION
with anti-stretch side reinforcement
Hardness 50 SH

**Contatto a sezione retta con protezione inox superiore antiusura
e inox laterale anti-allungamento**

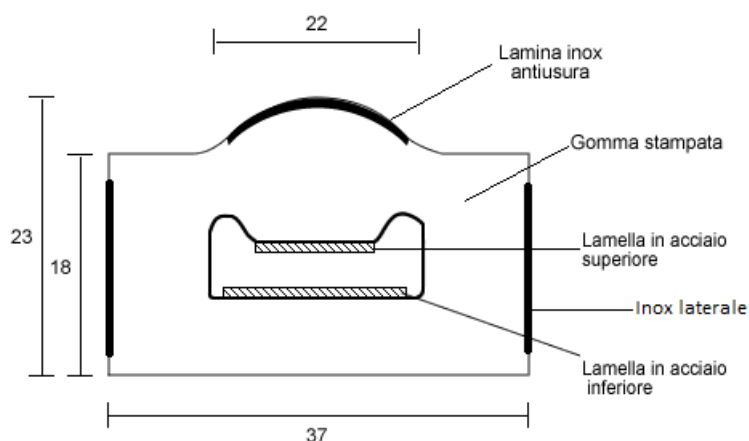

Guaranteed minimum performance characteristics	
<i>Passing speed of vehicles:</i>	0 ÷ 80 km/h
<i>Activation Pressure:</i>	10 ÷ 25 kg/cm ²
<i>Activation speed:</i>	< 1ms @ 12V
<i>Downtime:</i>	> 1 ms
<i>Operating Ambient Temperature:</i>	-30 ÷ 60° C
<i>Electrical resistance of the sensor at rest:</i>	> 500 MΩ
<i>Product Life Period:</i>	1 year or 2 million passes

Conditions to be met in order to guarantee the minimum life period of the product:

1. During installation and operation, the sensors should not be punctured or damaged with sharp objects.
2. The pull of the cable must not exceed 20kg.
3. The entire flat part of the sensor head must be protected by a sheet of steel.
4. During operation, the holder under the sensor must always be kept clean to prevent it from breaking.
5. The straight contacts must be glued to the support, both at the base and on the sides.

Date of last update: **20 / 06 / 2019**

Signature of the
Direction: _____