

PRODUCT DATA SHEET n° 1

**RECTANGULAR SECTION
HARDNESS 50 SH**

Contatto a sezione retta con protezione inox superiore antiusura

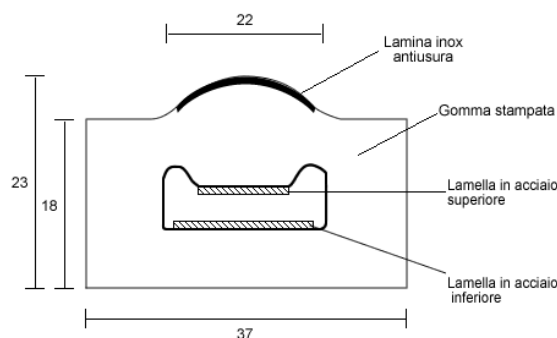

Guaranteed minimum performance characteristics	
Vehicle passage speed:	0 ÷ 80 km/h
Trigger pressure:	10 ÷ 25 kg/cm ²
Activation speed:	< 1 ms @ 12V
Downtime (inactivity) period:	> 1 ms
Environmental operating temperature:	-30 ÷ 60° C
Electrical resistance of the resting sensor:	> 500 MΩ
Product life period:	1 year, maximum 2 milion passes

Condition to be met in order for the minimum product life period to be guaranteed:

1. During the installation and operation phases, sensors should not be punctured or damaged with sharp objects.
2. The cable pull should not exceed 20kg.
3. The entire flat part of the sensor head should be protected by a steel plate.
4. During the operation, the holder under the sensor should be kept clean at all times to prevent the sensor from breaking.
5. The rectangular sensors, should be glued to the substrate, both at the base and sides.

Last Update date:

20 / 06 / 2019

Signature of the
Management:

UMBERTO PIANIGIANI srl
L'AMMINISTRATORE UNICO
(Dott. Cosimo Pianigiani)